



Compound Water Meter Model M-WT

A combination of 2 water meters - a large one, model WT, and a small one, model M- with a special change-over valve. This compound water meter can handle and measure accurately an extremely broad range of flow rates.

Features:

- Accurate measurement over broad range of flow rates
- Simple maintenance
- Field replaceable measuring units
- Hermetically sealed magnetic registers
- Optional electric output: EV and EF (volume & flow rate respectively) or DIALOG (see relevant leaflet)
- Dials include central "star" for easy leak detection

Applications

The Compound Water Meter is designed for applications requiring accurate measurements in environments with large fluctuations in flow rates, such as factories, hotels, hospitals, apartment buildings, etc.

Available Sizes

2" x 1/2", 3" x 3/4", 4" x 3/4", 6" x 1 1/4"

Technical Specifications

Maximum Working Pressure	Standard - 16 bar
Maximum Working Temperature	50° C
Body	Polyester coated WT meter - cast iron, M meter - copper alloy
Flanges	ISO, BS, AWWA (other - optional)



M-WT type dial



M type dial



Performance data:

Model M-WT			Qmax Maximum flowrate (m ³ /h)	Qn Nominal Flowrate (m ³ /h)	Change- over valve: opening flowrate (m ³ /h)	Change- over valve: Closing flowrate (m ³ /h)	Qt Transitional Flowrate (m ³ /h)	Qmin Minimum Flowrate (m ³ /h)	Starting Flow (l/h)	Maximum register capacity (m ³)	Accuracy between Qmax & Qt	Accuracy between Qt & Qmin
Nominal Size												
WT mm	WT inch	M inch										
50	2	1/2	65	40	1.5	1.2	0.12	0.03	11	10 ⁶	±2%	±5%
80	3	3/4	110	75	2	1.6	0.2	0.05	17	10 ⁶		
100	4	3/4	200	100	2	1.6	0.2	0.05	17	10 ⁷		
150	6	1 1/4	410	260	5	4.5	0.48	0.12	23	10 ⁷		

Dimensions

Model	M - WT				
Nominal size	(mm)	50	80	100	150
	(inch)	2	3	4	6
L – Length (mm)		270	330	350	495
B – Width (mm)		200	220	220	290
b – Width (mm)		100	100	100	145
H – Height (mm)		214	234	250	310
h – Height (mm)		70	90	106	130
Weight (kg)		17	23	34	63

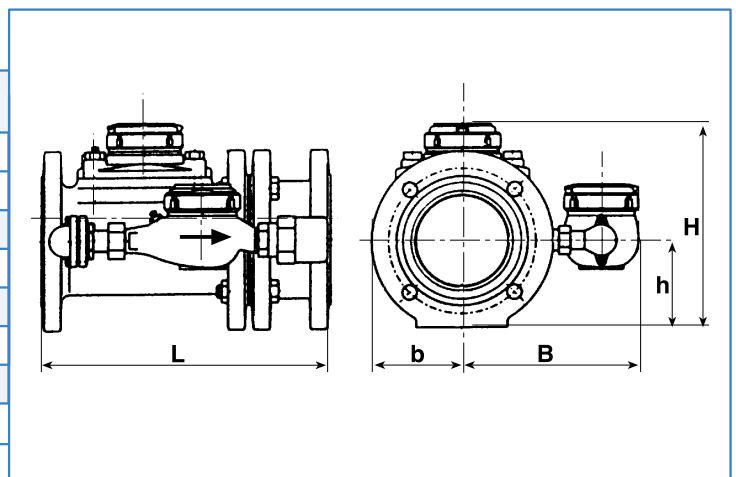

Head Loss Curve

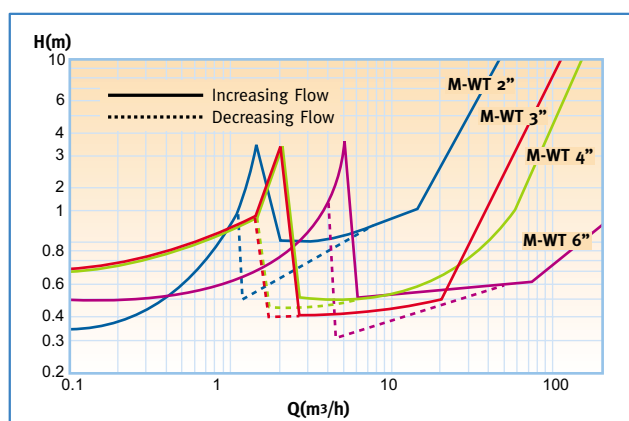

Installation Requirements

- The water meter should be installed in horizontal position.
- The meter shall be full of water while operating.
- Prior to installation of a meter, the pipeline shall be thoroughly flushed.
- Straight pipe section of the same diameter D as the meter, having length of 10D and 5D shall be installed upstream and downstream of the meter respectively.

